

PLATING CONTACT AREA:	
DASH NR:	PERFORMANCE LEVEL:
-1YY/1YYLF	TELCORDIA CO
-2YY/2YYLF	CUSTOMER SPECIAL
-3YY/3YYLF	CUSTOMER SPECIAL
-9YY/9YYLF	TELCORDIA CO

PC BOARD VERSIONS		
PRODUCT NR:	PCB THICKNESS	DIM "A"
89014-X02/X02LF	1.6	2.90
89014-X12/X12LF	2.4	3.53

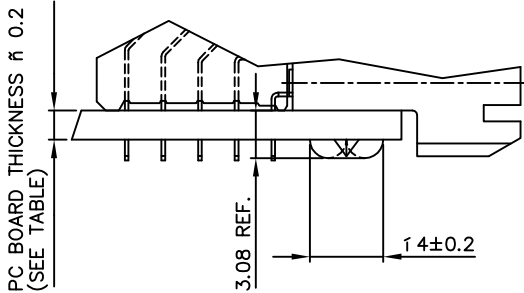
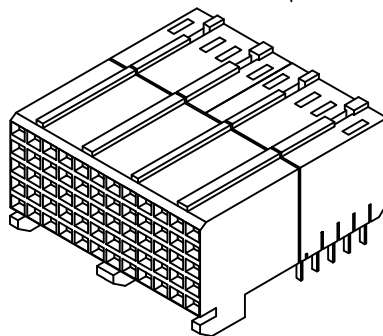
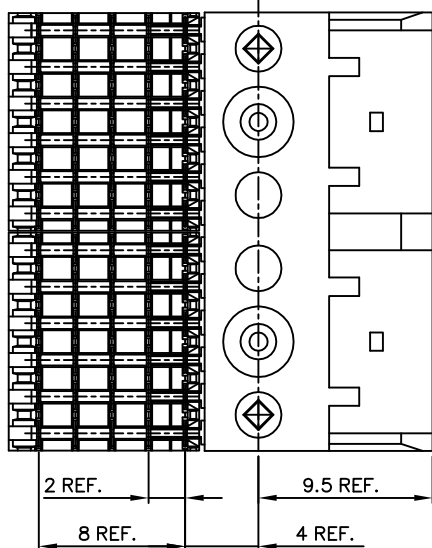
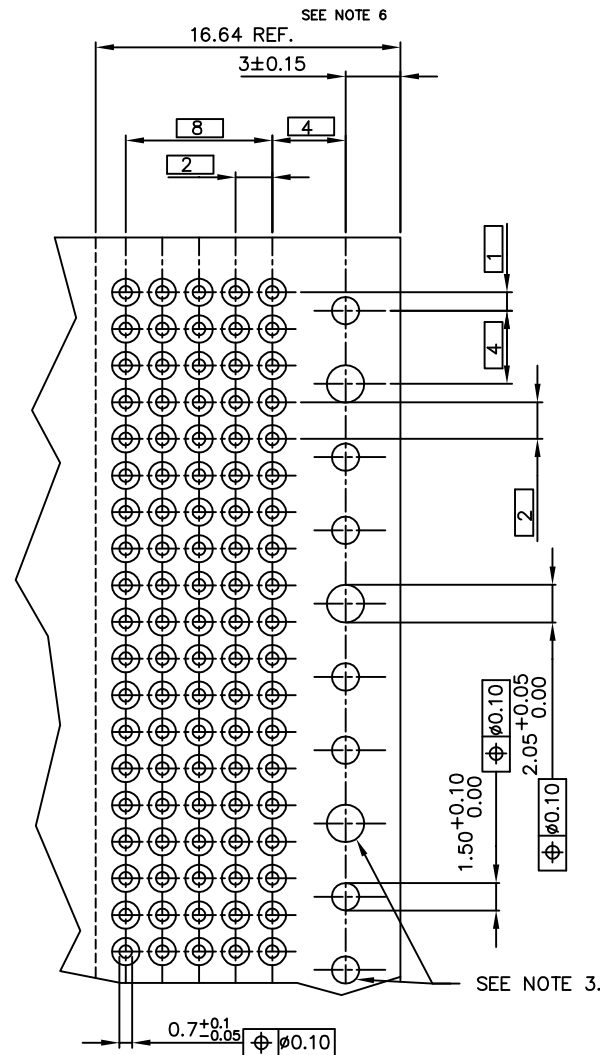
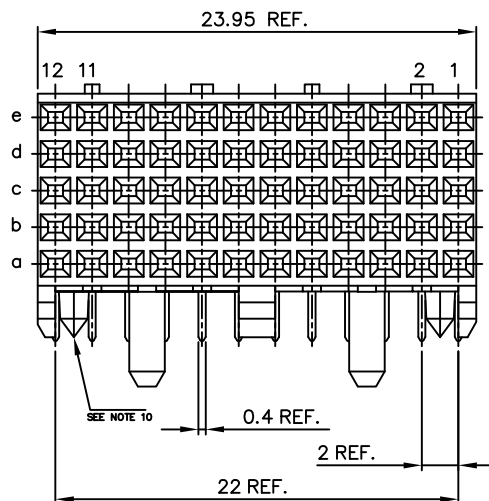
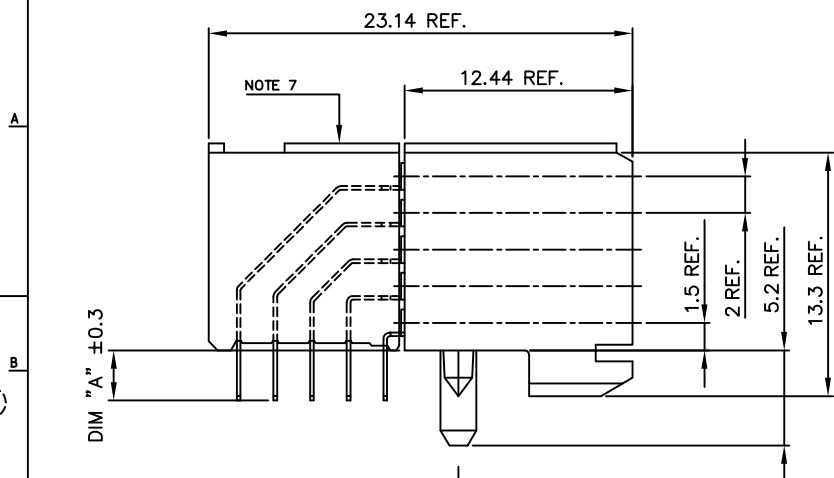

- NOTES:
- BODY MAT'L: LIQUID CRYSTAL POLYMER 30% GLASS
FLAME RETARDANT ACC. UL 94-V0
 - TERMINAL MATERIAL: PHOSPHOR BRONZE.
 - INDICATED HOLES ARE UNPLATED.
 - PLATING OF SOLDER TAILS 2-8 um SnPb 90-97 OR 2-8 um PURE Sn FOR LEAD FREE.
 - PRODUCT MARKING: PART NUMBER & BATCH ID.
 - SET BACK FOR TAIL BLOCK
 - TOP SURFACE OF PRESS BLOCK MAY EXTEND UP TO 0.4MM HIGHER THAN HOUSING. THIS MAY AFFECT THE TAIL LENGTH BEFORE APPLICATION TO A BOARD.
 - THIS PRODUCT MEETS EUROPEAN UNION DIRECTIVES AND OTHER COUNTRY REGULATIONS AS DESCRIBED IN GS-22-008.
 - THE HOUSING WILL WITHSTAND EXPOSURE TO 260DEGREE PEAK TEMPERATURE FOR 10 SECONDS IN A WAVE SOLDER APPLICATION.
 - DIAMOND LOCATION PEG ARE ONLY EXISTED ON THE BOTH SIDES OF PRODUCT.

RECOMMENDED HOLE PATTERN,
COMPONENT SIDE.

mat'l. code		tolerances unless otherwise specified		CUSTOMER COPY		FC ELECTRONICS	
ltr	ecn no	dr	date	linear	projection	title	www.falconconnect.com
A	H40101	VWQ	940209			5 ROW R.A. S.T.B. SIGNAL RECEPT. 24 mm MODULE	
B	H40487	DOB	940802				
C	V00578	LLA	000316	angles		product family METRAL (tm)	code
D	V00850	GNV	000512	dr	H v Woensel	940127	size
E	pc04-0104	CLU	041223	engr	H v Woensel	940127	no
F	D007-0170	Cent	05/22/07	chr	E Feijen	940127	scale
				app	H v Woensel	940127	5:1
sheet index	revision	F					
	sheet	1					